

INSULATION JUST GOT EVEN BETTER

ArmaGel[®] High-Temperature Application Manual

ArmaGel HT, ArmaGel HTL and ArmaGel XGH

Application Manual 3.0

www.armacell.com/armagel

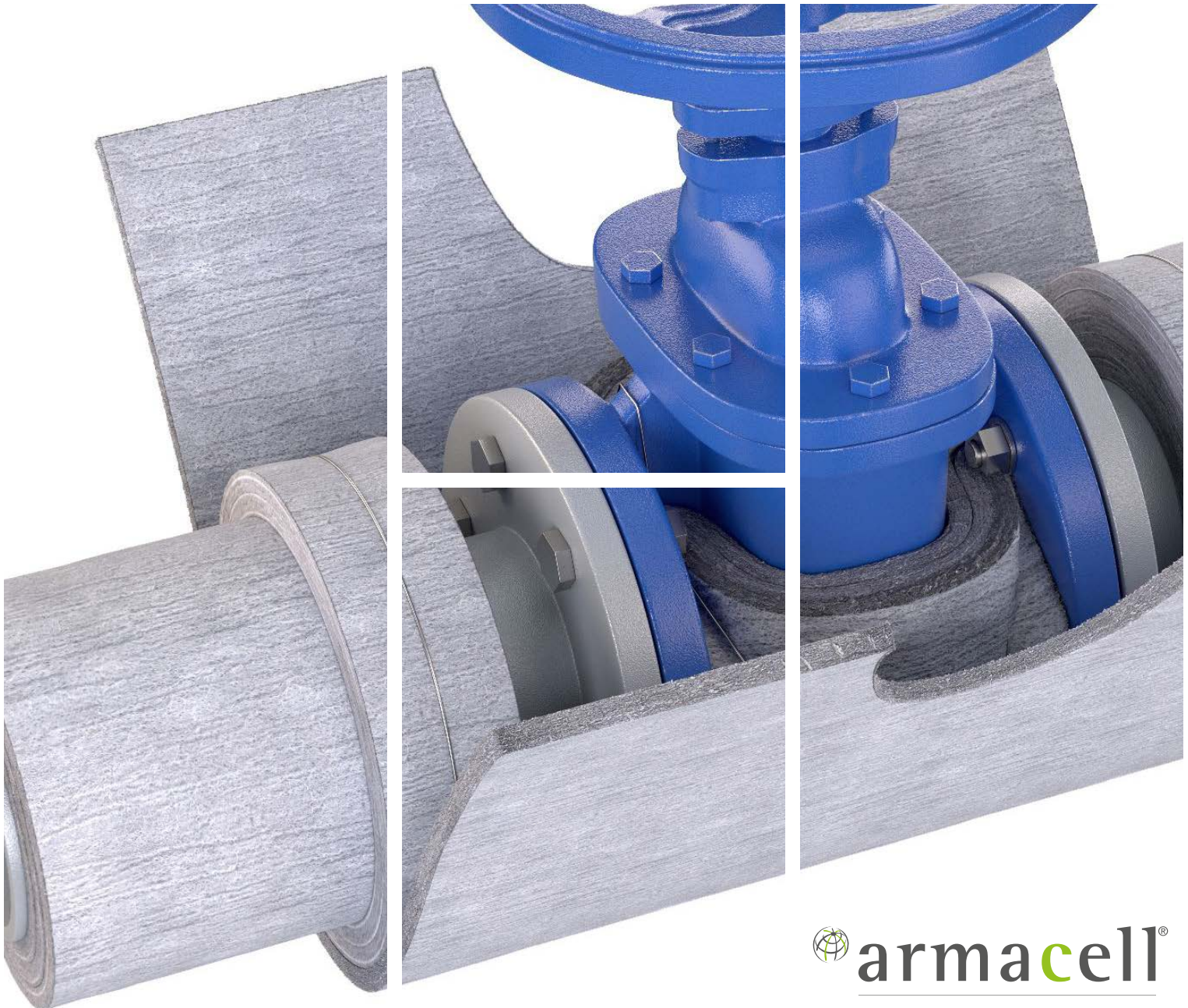

 **armacell**[®]
ArmaGel[®]



High-
temperature

About this manual

This application manual is designed to provide key application details for ArmaGel® HT, ArmaGel® HTL and ArmaGel® XGH.

Our vision has always been to create innovative technical insulation solutions and components to conserve energy and make a difference around the world. With aerogel that vision is now a reality. Say hello to the future of insulation today.

ArmaGel. Insulation just got even better.

ArmaGel HT and ArmaGel XGH the reliable solutions for high-temperature applications.

ArmaGel HTL the hydrophobic solution to mitigate corrosion under insulation.





CONTENT

04

PREPARATION

- 04 Before you start
- 05 Preparation
- 06 Site Requirements

07

KEY APPLICATION DETAILS

- 07 Essential Techniques
- 11 Multi-layering and Staggering
- 12 Cladding
- 13 High-temperature Application (>400°C)
- 16 Multi-Material (Hybrid) Systems Design

16

APPLICATION DETAILS

- 16 Spiral Wrapping
- 17 Flanges
- 18 Elbows and Bends
- 20 Two Piece Elbow Fitting Cover
- 23 Reducers
- 24 Equal Tees
- 25 Offset Tee, Oblique Angles
- 26 Pipe Trunnions
- 27 Gate Valves
- 29 Vessels / Equipment

30

APPENDIX

- 30 Accessory Fixing List

Before you start

Personal protective equipment (ppe) and safety considerations: ArmaGel will produce some amounts of dust - for your comfort some PPE measures are recommended.

Working with ArmaGel



Figure 1:
PPE Equipment

ArmaGel will produce some amounts of dust and fibers during handling and cutting which must be managed in accordance with local regulations. See ArmaGel safety data sheet at www.armacell.com/armagel.

For worker comfort we recommend the PPE shown above. Dust mask (disposable filtering half mask, class FFP2 acc. to EN 149, N95 American NIOSH Standard or equivalent).



Note

Masks should be properly fitted and worn in accordance with the manufacturer's instructions. Users are advised to be cleanly shaven.

Material Handling and storage



Figure 2:
Correct storage conditions

ArmaGel rolls must always be laid / stacked sideways, never on end and always stored under cover and in dry conditions.

Preparation

- Retractable craft (Stanley) type knife
- Electric / battery operated shears
- Heavy duty scissors
- Straight edge
- Set square
- Dividers and calipers
- Tape measure
- Wire cutting tool
- Pliers / tin snips
- Banding tensioning tool

Prefabrication and Preparation in the Workshop

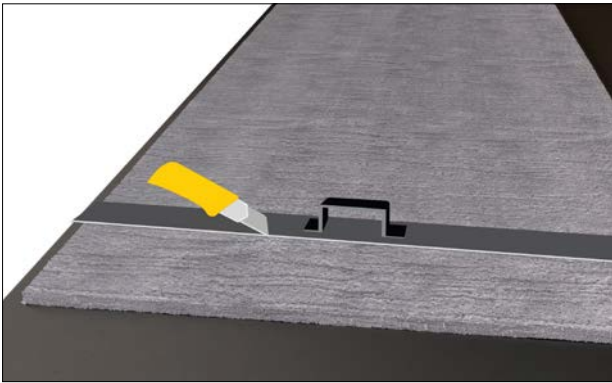

Figure 3:
Prefabrication cutting in the workshop



Figure 5:
Prefabricated parts ready to transport to jobsite



Figure 4:
Recommended tools for fabrication of ArmaGel

Simple tools are required for measuring, marking and cutting.

Prefabricated parts for straights and fittings can be prepared and palletised. Protect from adverse weather.



Note

Within workshop locations, as part of good housekeeping, the use of an industrial type vacuum for cleaning of aerogel dust is recommended.

Site requirements

Ensure that the jobsite conditions are optimal. Protect the insulation from adverse weather.

Weather and Equipment Conditions



Figure 6:
Ensure that piping is clean, dry and free from contamination

Enclosures / tenting may be required if rain or bad weather is expected during installation. Do not install ArmaGel if weather conditions are unsuitable (eg. rain, condensing fog, snowfall, ...).

Key Application Details

Accurate circumference measurement ensures tightly closed seams. Wrap ArmaGel tightly to avoid gaps or voids. All ArmaGel types can be fabricated in widths less than 1.5m, for ease of application on small bore pipes - 1" to 4" NB, for example 500mm.



Figure 7:
Circumference measurement

Measure circumference of pipe using a strip of ArmaGel to ensure accurate tight longitudinal butt or overlap seam (25-50 mm overlap). Either jointing method is acceptable. For single layer applications a 20-50mm overlap should be added to the circumference sizing if required.



Figure 8:
Longitudinal overlapped seam

Wrap ArmaGel tightly around pipe to avoid gaps or voids.



Figure 9:
Longitudinal seam is tightly butted showing no pipe / insulation surface below



Figure 10:
Circumferential and longitudinal seams are tightly butted showing no pipe / insulation surface below



Note

All XGH fabricated insulation parts when cut before application, can be pre-rolled around pipe surface to release surface tension of material, allowing for the material to be installed easier around pipe surface/s during fixing. Applicable for 5mm, 10mm & 20mm thickness.



Note

It is recommended to use bevel cuts (22.5 - 45° angle cuts) on 15mm & 20mm blankets for longitudinal joints in order to enhance the closure of the joints (Applicable for HT & HTL). For 20mm XGH blanket on smaller pipe sizes 4" - 6" NPS bevel cuts can be implemented on one longitudinal mating edge if required.

Key Application Details

Ensure that the all seams are closed evenly and secured tightly without gaps. ArmaGel must always be secured with insulation binding wire or bands. Longitudinal seams shall always be oriented at the side. For enhanced closure of ArmaGel XGH seams , additional wires / bands are applied.



Figure 11:
ArmaGel layer secured by steel wires or bands



Figure 12:
Rotate longitudinal seams to side

Longitudinal and circumferential seams/joints shall be tightly butted without any visible gaps.

Each layer of ArmaGel (or the final layer of a continuous wrap) must always be secured using either 0.5-1 mm thick stainless steel wires or 13/19 mm (1/2, 3/4 in.) wide x 0.5mm thick metal bands and clips for larger diameters. For ArmaGel HT & HTL, a maximum separation of wires shall be 200 mm (8 in.) and maximum separation of band centres shall be 200 - 300 mm (8-12 in.) depending on pipe size. Additional wires / bands are applied when installing ArmaGel XGH - see recommended spacing of wires/bands in table below.

Always rotate the longitudinal seam to the side, never at the top.

Circumferential butt joints shall be pushed tightly together to avoid gaps.

Table 1: Suggested Securement Method & Spacings for ArmaGel XGH / HT/ HTL

Pipe size (NB - inch)	Binding wire (0.5mm thick)	Binding wire (1.0mm thick)	Bands 13mm wide x (0.5mm thick)	Bands 19mm wide x (0.5mm thick)	Maximum spacing of bonding wire* / bands** (mm)	
					HT/HTL	XGH
1	Yes	No	No	No	200*	50*
1½	Yes	No	No	No	200*	50*
2	Yes	No	No	No	200*	75*
2½	Yes	No	No	No	200*	100*
3 & 4	Yes	No	No	No	200*	100*
6 to 18	No	Yes	No	No	200*	150*
20 & above	No	No	Yes	Yes	300**	250**
Vessel & Equipment	No	No	No	Yes	300**	300**

Notes:

- Insulation parts installed around piping, bends, tees and other pipe fittings, additional wires and bands applied as necessary for securement and better closure of longitudinal joints too avoid gaps showing pipe / insulation surface below.
- For pipe sizes 1", 1½ & 2" binding wire can be spiral bound around the circumference of the insulation surface at maximum 50mm centers.
- All Fixings to be in stainless steel.

Key Application Details

Table 2A: Recommended minimum pipe size for various ArmaGel HT and HTL blanket thickness on straight piping

Nominal Pipe Size (inch)	Actual Outer Diameter (mm)	ArmaGel HT/HTL Insulation Blanket Thickness (mm)			
		5	10	15	20
< 1	< 35	✓	✗	✗	✗
1	35	✓	✓	✗	✗
2	60	✓	✓	✗	✗
3	89	✓	✓	✓	✗
4	114	✓	✓	✓	✓
6	168	✓	✓	✓	✓
≥ 8	≥ 219	✓	✓	✓	✓

Notes:

- ✓ Indicates blanket thickness that can be used when bending round a given pipe size.
- ✗ not recommend.
- Outer diameter (mm) of pipe size can also be used for the outer diameter of a flanged fitting when applying ArmaGel.

Table 2B: Recommended minimum pipe size for various ArmaGel XGH blanket thickness on piping

Nominal Pipe Size (inch)	Actual Outer Diameter (mm)	ArmaGel XGH Insulation Blanket Thickness (mm)		
		5	10	20
½ & ¾	21 & 27	✓*	✗	✗
1 & 1½	35 & 42	✓*	✓	✗
2	60	✓	✓	✗
3	89	✓	✓	✗
4	114	✓	✓	✓
6	168	✓	✓	✓
≥ 8	≥ 219	✓	✓	✓

V-grooving is not required for any type of ArmaGel material for smaller pipe sizes.

Notes:

- ✓ Indicates blanket thickness that can be used when bending round a given pipe size.
- ✗ Not recommend.
- * Optional spiral bandaging method. (Typical for single layer applications only)

Key Application Details

Table 3: Straight Piping – Typical Fabrication / Installation Methods for XGH 5mm, 10mm & 20mm Thick

Nominal Pipe Size (inch)	Traditional Standard Method			Spiral Wrapping Method		
	5mm Thick	10mm Thick	20mm Thick	5mm Thick	10mm Thick	20mm Thick
½ - ¾	Yes	No	No	Yes*	No	No
1	Yes**	Yes**	No	Yes*	Yes*	No
1½	Yes**	Yes **	No	Yes*	Yes*	No
2	Yes**	Yes **	No	No	No	No
2½	Yes**	Yes **	No	No	No	No
3	Yes**	Yes **	No	No	No	No
4	Yes**	Yes**	Yes**	No	No	No
6 & above	Yes	Yes	Yes	No	No	No

Notes:

1. Recommended that insulation parts be cut and fabricated for ease of installation in 500mm**, 750mm & 1500mm width parts depending on pipe size and thickness. (3 x 500mm) or (4 x 375mm) insulation part widths = 1500mm in total, equivalent to the standard supplied width of ArmaGel XGH material.
2. *Optional spiral bandaging method. (Typical for single layer applications only)

Key Application Details

Multi-layering staggering of longitudinal and circumferential seams



Figure 13:
Staggering of next layer of ArmaGel.

Joints and seams shall be staggered minimum 100 mm (4 in.) circumferentially, longitudinally and between layers.



Figure 14:
Securement of ArmaGel with stainless steel wires.

Each layer of ArmaGel (or the final layer of a continuous wrap) must always be secured using either 1 mm thick stainless steel wire or 13 / 19 mm (1/2, 3/4 in.) wide x 0.5mm thick metal bands and clips for larger diameters. Maximum separation of wires shall be 200 mm (8 in.) and maximum separation of band centres shall be 200 - 300 mm (8-12 in.) depending on pipe size applicable for ArmaGel HT and HTL. Additional wires/bands to be applied to enhance the closure of longitudinal seams for ArmaGel XGH applications, see Table 1.

Continuous wrap method



Figure 15:
ArmaGel continuous wrap

Ensure starting point is in line with axis of pipe. Tape or adhesive may be required to help hold the axial position. For ease of application 500 to 750mm wide sections of material can be used.



Figure 16:
ArmaGel continuous wrap

Continue to wrap around the pipe to achieve the required quantity of layers. End the wrap with the longitudinal edge in line with, or overlapped with, the inner layer starting point.

Key Application Details

Cladding

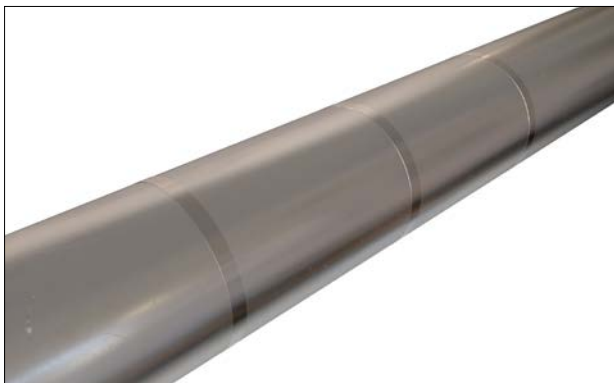

Figure 17:
Apply cladding.

ArmaGel shall always be protected by a jacketing / cladding when installed outdoors. This is also recommended for indoor applications.



Figure 18:
Do not leave insulation unprotected.

Unfinished insulation during installation process shall be adequately protected from weather such as rain, snow and other adverse conditions by the use of temporarily protective covering such as PE sheeting until the insulation system is completed with permanent cladding system.

ArmaGel HT and ArmaGel XGH Key Application Details

Leave no gaps. > 250 °C (480 °F), do not use organic adhesives or tapes.
> 400 °C (752 °F), intermediate layer of metallic foil required.

This section is only applicable to ArmaGel HT and ArmaGel XGH installation

All high-temperature insulation materials may release traces of organic residues during initial commissioning and exposure to high temperatures. This process may be accompanied by the emission of gaseous products and their oxidation, and consequently, a short-term exothermic reaction, which may be accompanied by a specific odour, smoke release, and in extreme cases glowing and/or flaming.

1. To ensure that any self-heating and/or exothermic reaction for operating temperatures above 400 °C is kept within an acceptable range, the following application instructions shall be followed:
 - a. All layers of ArmaGel HT and ArmaGel XGH shall be installed and secured tightly to avoid any visible gaps between layers and along all longitudinal and circumferential joints.
 - b. The metallic foil (e.g., aluminium/stainless steel foil) shall be installed between the two outmost layers of the ArmaGel HT/XGH construction.
 - c. The cladding system shall be fully installed before operating the pipe/equipment.
2. Do not apply ArmaGel HT/XGH on live pipe/equipment when operating above 350 °C and ensure that the insulation system is complete before turning the pipe/equipment on.
3. Do not apply ArmaGel HT/XGH with a total thickness of more than 80mm without first contacting Armacell technical support.

High temperature Application - Line Temperatures above 400°C



Figure 19:
Termination next to a flange



Figure 20:
Termination next to a flange: bolt clearance

At insulation layering termination ends next to flanged fittings leave enough space to allow for bolt removal (bolt length plus 25/50mm clearance).



Note

Do not apply ArmaGel HT / XGH on live pipe/equipment when operating above 350 °C.

ArmaGel HT and ArmaGel XGH Key Application Details

High temperature Application - Line Temperatures above 400°C (continued)



Figure 21:
Metallic foil application

Apply metallic foil (minimum 0.05mm thick) around the entire surface area of the outer insulation surface of the 2nd last insulation layer.

Do not apply any type of PET laminated type foils. The overlap should be minimum 100mm.

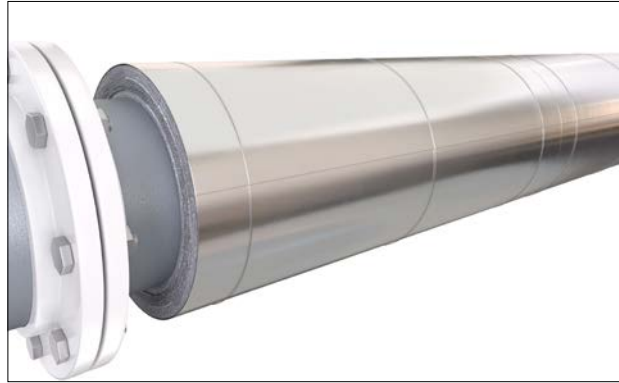

Figure 22:
Metallic foil at termination

Fix and secure the foil with insulation wire.

No self-adhesive tape or adhesive shall be used to secure down the foil overlap.



Figure 23:
ArmaGel HT final layer.

Apply final outer layer of ArmaGel HT/XGH over the top of the metallic foil.



Figure 24:
Positioning of final layer.

Next to the flange fitting termination, position ArmaGel in-line with the other layering terminations.



Note

The metal cap end should not be in direct contact with the pipe surface.

ArmaGel HT and ArmaGel XGH Key Application Details

High temperature Application - Line Temperatures above 400°C (continued)



Figure 25:
Metal cap-end termination.

Apply a metal cap-end to the exposed ArmaGel HT/ XGH termination layers. The metal cap end should be the same type and thickness as the intended outer metal jacket.

The cap end shall be isolated from the pipe surface by using high temperature insulation bandage or ArmaGel.

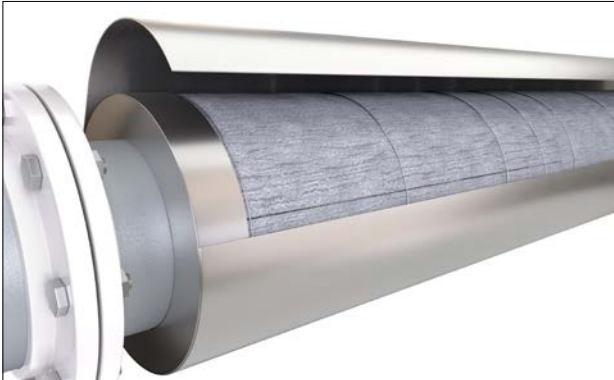

Figure 26:
Metal jacketing over cap-end.

Apply metal outer jacket throughout.



Note
The metal cap-end can be installed after the straight section of cladding has been applied if required.



Figure 27:
Completed metal jacketing.

Fix and secure as required with bands, screws or rivets.

If required by the project specification – insert drain holes into the cladding.



Note
The metal cap end should not be in direct contact with the pipe surface.

Application Details

Multi-Material (Hybrid) Systems Design

- For multi-material systems, where ArmaGel HT/XGH is used in combination with other insulation materials, the operating / line temperatures should not exceed 400°C.
- However, if a multi-material design with operating temperatures above 400 °C is required, a mock-up / trial shall be performed to replicate the exact configuration and operating conditions for its intended use. This is to verify the system performance and confirm suitability in operation.
- For multi-material systems with operating temperatures between 250 °C and 400 °C, where ArmaGel HT/XGH is used as inner layers in combination with another insulation material applied on top, a metallic foil of min. 0.05mm thickness must be installed over the final layer of ArmaGel HT/XGH.
- For multi-material systems with operating temperatures below 250 °C, where ArmaGel HT/XGH is used in combination with other insulation material, a layer of metallic foil on the final layer of ArmaGel HT/XGH is not required.

Spiral wrapping of small bore pipes (alternative method)



Figure 28:
Spiral bandage application.

Wrap 50 or 100 mm wide strips of ArmaGel around pipe. Material is overlapped by 50%.

Refer to table 2A/B and 3 for the recommended minimum pipe size for various ArmaGel HT, HTL and XGH blanket thickness using traditional installation method.



Figure 29:
Securement of bandage.

Secure the bandage with insulation wire / bands.



Note

For 5mm ArmaGel XGH, spiral wrapping is recommended on 1/2 - 1.1/2" NPS piping

Application Details

Flanges (Typical method)



Figure 30:
Flange insulation.

Insulate close to flange, note clearance for bolt removal may be required.



Figure 31:
Build up Flange insulation .

Wrap 50mm (2ich) wide strips of ArmaGel to build up insulation to clear flange (or adjust width to be equal to total insulation thickness).



Figure 32:
Insulation flange cover.

Wrap to same thickness as ArmaGel on pipe.



Figure 33:
Securement of flange insulation cover.

Secure flange cover with insulation binding wires or steel bands and clips.



Note

If required for bolt removal leave appropriate distance between the flange face and the termination of the pipe insulation.

Do not use different types of ArmaGel when applying on flanges. Use the same type and thickness as connecting pipe unless specifically advised.

Application Details

Elbows and Bends (Applicable for ArmaGel HT/HTL & XGH)

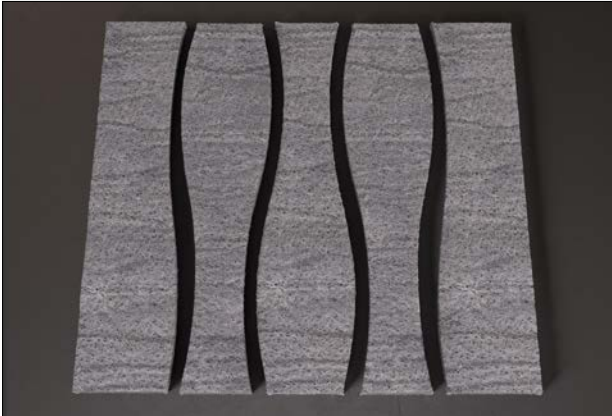

Figure 34:
Typical segment design (For use with HT/HL and XGH).

Cut segments to suit exact circumference and inside radius of pipe. Remember to allow a half starter / finisher piece.



Figure 35:
Segment installation.

Ensure all joints are closely butted without gaps and that they fit the pipe tightly without voids.



Figure 36:
Securement of segments using insulation wire.

Wire each gore in place allowing movement for final adjustment. Use bands if required depending on pipe size.



Figure 37:
Completion of segment installation.

Push all segments together to ensure there are no gaps at joints and tighten wires.

For single layer applications, overlapping of longitudinal seams can be applied if required. For multi-layering applications, fabricate the segment dimensions smaller or larger too provide the staggering of all seams and joints.

Table 4: 90° Welded Bends – Typical Fabrication / Installation Methods For XGH 5,10 & 20mm

Pipe Size. NB - (inch)	Segments (Gores)	Other (Elbow 90 Fitting)
1	No	Yes
1¼	No	Yes
1½	No	Yes
2	Yes	No*
2½	Yes	No*
3	Yes	No
4 & above	Yes	No

Note:

* Elbow 90 at pipe size may be required where applicable within Project Specification.

Application Details: Two Piece Elbow Fitting Cover (Not applicable for ArmaGel XGH material)

How to fabricate / install a two piece elbow fitting cover using ArmaGel HT & HTL.

Measuring and marking out - Creating the Template Pattern

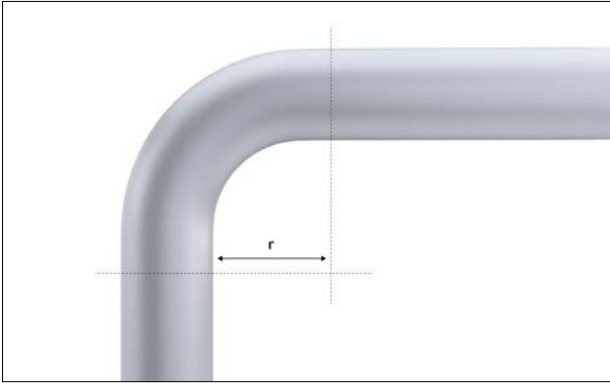

Figure 38:
Measuring the inside radius "r".

Establish the inside radius, "r", by dropping a perpendicular line to meet a horizontal line from the outside of the two welds. Fig 38.

The point where these two lines intersect gives the origin for the radius, r. This is the throat radius.



Figure 39:
Circumference measurement.

Measure in a trimming allowance (determined by the insulation thickness) along both vertical and horizontal edges then transfer to the sheet as indicated in Fig 40.

Determine the circumference of the pipe using a strip of ArmaGel of the thickness to be installed in Fig 39.

Creating the template pattern

Metal cladding sheeting can be used to create the applicable template).

Halve the pipe circumference and transfer this dimension to the metal cladding sheet.

Mark out the two arcs from the intersection of the trim lines and the other formula dimensions onto the template as shown in Fig 40.

Formula:

r = inside radius of bend.

c = half of pipe

t = insulation thickness (in mm)

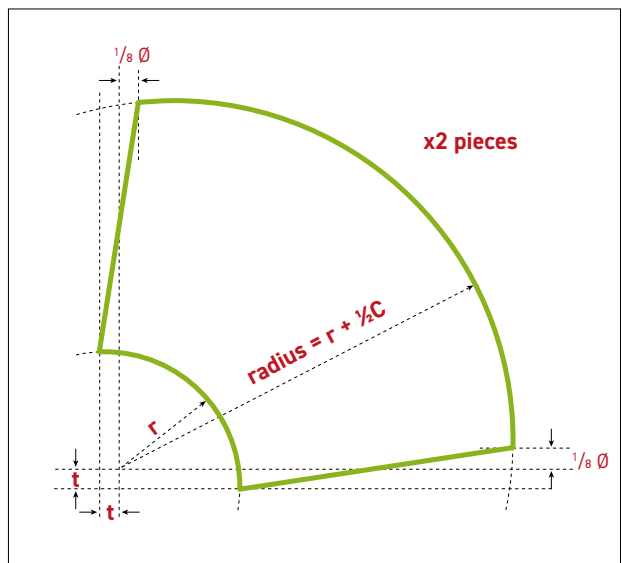

Figure 40:
Template pattern for two-piece bend.

Application Details: Two Piece Elbow Fitting Cover (continued)

Cutting out of two-piece fitting covers

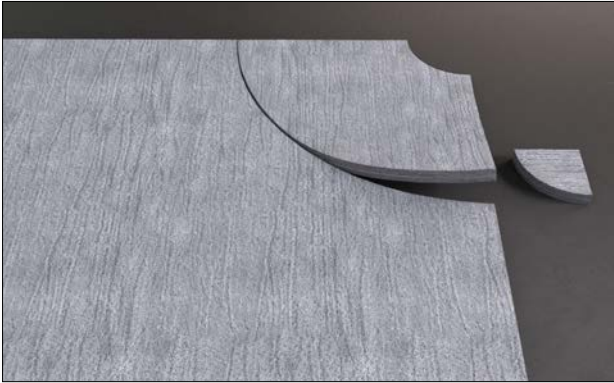

Figure 41:
Cutting out of fitting cover.

Transfer the template onto the ArmaGel material.

With a sharp retractable craft knife cut out the required number of elbow parts (two per elbow fitting). Fig 41.

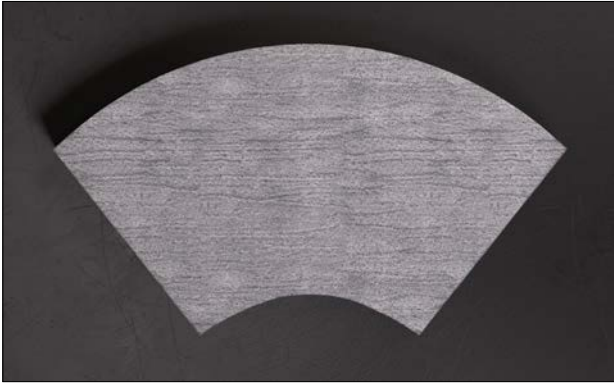

Figure 42:
Fitting cover without overlap.

If overlaps are required, the inside and outside radius of two piece bend can be added with 10-25mm overlap (refer Fig 43). Only one half of the two piece bend cover needs the overlap.

Fig 44 shows two piece bend construction without overlap.

Installing the Two Piece Bend Fitting Cover

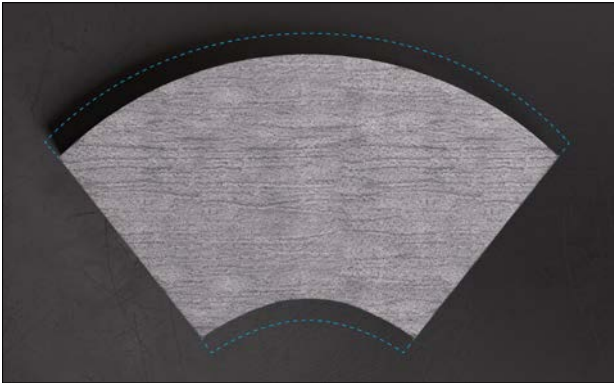

Figure 43:
Fitting cover with overlap.



Figure 44:
Multiple view of two-piece bend installation.

Using insulation wires or bands to fix and secure the insulation parts at both ends and at intervals to enable suitable closure of the seams. If required the insulation wire can be spirally wound around the fitting cover.



Note

If required two-piece bend fitting cover can be applied with overlaps.

Adding overlaps can increase the sizing required for additional insulation layers and outer jacketing/cladding.

Application Details: Two Piece Elbow Fitting Cover (continued)

Table 5: Recommended minimum pipe size for ArmaGel two-piece bend blanket thickness on elbow.

Applicable for ArmaGel HT/HTL (thickness of ArmaGel blanket that can be used to install a ArmaGel two-piece bend fitting cover)

Nominal Pipe Size (inch)	Actual Outer Diameter (mm)	ArmaGel HT/HTL Insulation Blanket Thickness (mm)			
		5	10	15	20
< 1	< 35	✓	✘	✘	✘
1	35	✓	✓	✘	✘
2	60	✓	✓	✘	✘
3	89	✓	✓	✓	✘
4	114	✓	✓	✓	✓
6	168	✓	✓	✓	✓
≥ 8	≥ 219	✓	✓	✓	✓

Notes:

- ✓ Indicates blanket thickness that can be used when bending round a given pipe size.
- ✘ not recommend.

Application Details

Reducers



Figure 45:
Measuring pipe circumference.

Measure both circumferences over the weld.



Figure 46:
Cutting of reducer pattern.

Fabricate pattern and cut out with sharp knife.



Figure 47:
Securement of reducer.

Fit the insulation piece around reducer with insulation binding wires. Stainless steel bands can be used if required depending on pipe size.

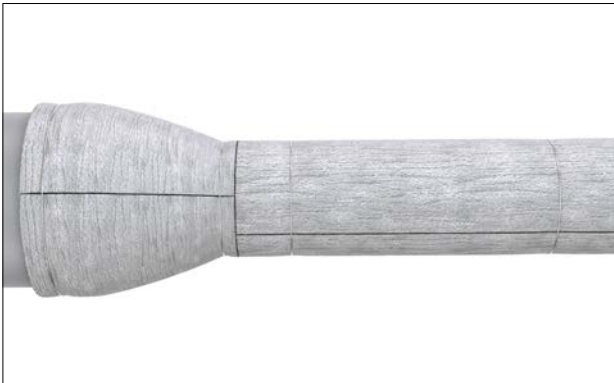

Figure 48:
Reducer with insulation straight connection.

All seams and joints of insulation shall be butted tightly without any visible gaps.



Note
For single layer applications overlap connecting ends of material.

Application Details

Equal Tees



Figure 49:
Tee body cover.

Insulate main pipe around tee connection, ensure cut out is clean and tidy.

Secure insulation cover with insulation binding wires or bands at 200mm (8in.) centres. Additional wires/bands are applied when installing ArmaGel XGH - see recommended spacing of wires/bands in table 1.



Figure 51:
Installation of tee cover.

Secure insulation tee cover with insulation binding wires or bands depending on pipe size.



Figure 50:
Fabrication of tee cover.

Cut with a clean, sharp knife.



Note

Ensure there are no visible gaps within the seams and butt joints.

Application Details

Offset Tee, Oblique Angles



Figure 52:
Oblique cut out.

Create cut out for oblique angled branch.



Figure 53:
Tee body cover.

Wrap around pipe and secure with insulation binding wires or bands depending on pipe size.



Figure 54:
Oblique tee connection insulation cover.

Fabricate pattern and cut material to fit the oblique angled branch.



Figure 55:
Completed tee cover.

Install oblique angled branch and secure with insulation binding wires or bands. Ensure that all seams and joints are tightly butted without any visible gaps. For single layer applications, an overlap of branch onto connecting tee can be applied if required.

Application Details

Pipe Trunnions



Figure 56:
Typical trunnion example.

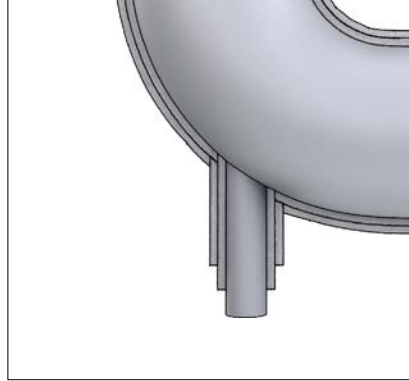

Figure 57:
Typical trunnion construction example.

Trinnion connection to be fabricated and installed as detailed typically within Figures 56 and 57.

Application Details

Gate Valves (Typical Method)



Figure 58:
Preparation for valve cover.

Wrap strips of ArmaGel around the insulated pipe until the insulation is equal to or exceeds the outside diameter of the flange.



Figure 59:
Packing out of air-space.

Using scrap pieces of ArmaGel pack out the air-space void within the valve body.



Figure 60:
Valve body cover.

Determine the appropriate size of insulation to fit around the circumference of the valve body. Cut out insulation to accommodate the connecting bonnet.



Figure 61:
Insulation at valve body.

Install the insulation cover over the valve body. Fix and secure ArmaGel with insulation binding wires or bands and clips. Ensure there are no visible gaps at all seams and joints.



Note
Do not use different types of ArmaGel when applying on valves. Use the same type and thickness as connecting pipe unless otherwise advised by Project Engineer/ Project specification.

Application Details

Gate Valves (spindle bonnet connection)



Figure 62:
Fabricate spindle bonnet cap.

Fabricate the spindle / bonnet cap as shown.

Fabricate appropriate spindle / bonnet tee fitting cover.



Figure 63:
Installing spindle bonnet tee fitting cover.

Apply ArmaGel caps and fitting cover tightly around the spindle bonnet connection and secure with insulation binding wires or bands and clips.

Ensure there are no visible gaps at all seams and joints.



Note

Ensure that all connecting seams and joints are tightly butted without any visible gaps showing metal / insulation surface below.

Application Details

Vessels / Equipment



Figure 64:
Typical vessel body.

Insulate from the vessel head weld line. Secure ArmaGel sheet panels with insulation welded pins and 19mm wide stainless steel bands and clips, staggering all seams and joints as shown in Fig 64 above.

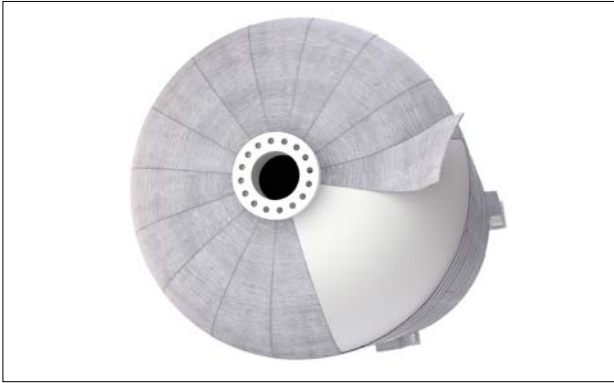

Figure 65:
Vessel Head Segmentation.

Install segments as required ensuring there are no visible gaps between seams and joints. Secure the insulation segments with stainless steel bands and welded pins (if required). Floating rings can be used with stainless steel bands to secure the insulation segments. (Refer to project specification for fixings and securement for vessel insulation).



Figure 66:
Panel Multi-layering.

Fixing and securement as above in Fig 66. Ensure the panel seams are staggered away with minimum 100mm from the butted seams of the previous layer.



Note

- Banding to be applied at maximum 300mm centers.
- For multi-layering application stagger all seams and joints (additional bands can be applied where required).
- For single layer applications – overlap of all connected insulation panels in all directions can be applied if required.

Appendix

Insulation Material

Insulation material	Material Description
ArmaGel HT 5mm sheet	High performance aerogel blanket of 5mm thickness
ArmaGel HT 10mm sheet	High performance aerogel blanket of 10mm thickness
ArmaGel HT 15mm sheet	High performance aerogel blanket of 15mm thickness
ArmaGel HT 20mm sheet	High performance aerogel blanket of 20mm thickness
ArmaGel HTL 5mm sheet	Hydrophobic aerogel blanket of 5mm thickness
ArmaGel HTL 10mm sheet	Hydrophobic aerogel blanket of 10mm thickness
ArmaGel HTL 20mm sheet	Hydrophobic aerogel blanket of 20mm thickness
ArmaGel XGH 5mm sheet	High performance aerogel blanket of 5mm thickness
ArmaGel XGH 10mm sheet	High performance aerogel blanket of 10mm thickness
ArmaGel XGH 20mm sheet	High performance aerogel blanket of 20mm thickness

Accessory Fixing List

Fixings Accessory & Suggested Product(s)	Material Description	Areas of Use
Insulation (Binding) wire - soft-annealed:	Stainless Steel (SS) , according to ASTM A167, type 304	Fixing and securing of insulation material on piping applications. Pipe sizes from ½" to 18" typically.
	Fe 360 B galvanized. Dimensions: diam. 0.5 to 1.0 mm	
Tensioning Metal Bands:	Aluminium 99.5 (1S) 1/2 hard (H14).	Fixing and securing of insulation material on piping applications.
	Stainless Steel (SS) , according to ASTM A167, type 304	
	Fe 360 B Aluzinc	Refer to table 1
	Fe 360 continuous hot dip (Sendzimir) galvanized	Refer to table 1
	Dimensions: 13 x 0.5 mm, 19 x 0.5 mm and 25 x 0.5 mm	

Appendix

Accessory Fixing List (continued)

Fixings Accessory & Suggested Product(s)	Material Description	Areas of Use
Seals for Tensioning Bands (wing type)	Aluminium 99.5 (1S) 1/2 hard (H14). Stainless Steel (SS) , according to ASTM A167, type 304 Fe 360 B Aluzinc. Fe 360 B electrolytically galvanized.	Used with Tensioning bands.
Self-tapping screws:	Stainless Steel (SS), according to ASTM A167, type 304 Aluminium or galvanized steel. Dimensions: 4.2 x 13 mm or 4.8 x 13 mm	To fix and secure metal jacketing.
Blind rivets:	Stainless Steel (SS), Aluminium or galvanized steel. Dimensions: 3.2 x 10 mm, length to be determined on site 4.8 x 10 mm, length to be determined on site	To fix and secure metal jacketing.
Self-tapping screws with integrated EPDM seal ring.	Stainless Steel (SS), according to ASTM A167, type 304 or galvanized steel. Dimensions: diameter 4.2 x 13 mm, 4.8 x 13 mm or 6.3 x 30 mm	To fix and secure metal jacketing.
Stainless steel sheet: in acc. with ASTM A 240M type 304.	Sheet thickness: 0.5 mm, 0.6 mm, 0.8 mm and 1.0 mm Max. surface temperature: 900°C (Temperatures above 500°C cause colour change)	Piping and Vessels Equipment.
Continuous hot dip (Sendzimir) galvanized steel sheet.	Sheet thickness: 0.5 mm and 0.8 mm Max. surface temperature: 400°C	Piping and Vessels Equipment.
Aluzinc steel sheet	Steel sheet provided with a aluminium-zinc alloy layer: in acc. with ASTM A 792M. Aluminium-zinc alloy layer thickness: 185 g/m ² in total for both sides; 25 µm each side. Max. surface temperature: 315°C (Temperatures above 315°C cause colour change. The protective action is retained at temperatures up to 700°C). Sheet thickness: 0.5 mm and 0.8 mm	Piping and Vessels Equipment.

All data and technical information are based on results achieved under the specific conditions defined according to the testing standards referenced. Despite taking every precaution to ensure that said data and technical information are up to date, Armacell does not make any representation or warranty, express or implied, as to the accuracy, content or completeness of said data and technical information. Armacell also does not assume any liability towards any person resulting from the use of said data or technical information. Armacell reserves the right to revoke, modify or amend this document at any moment. It is the customer's responsibility to verify if the product is suitable for the intended application. The responsibility for professional and correct installation and compliance with relevant building regulations lies with the customer. This document does not constitute nor is part of a legal offer to sell or to contract.

At Armacell, your trust means everything to us, so we want to let you know your rights and make it easier for you to understand what information we collect and why we collect it. If you would like to find out about our processing of your data, please visit our Data Protection Policy.

© Armacell, 2025. ArmaGel® is a trademark of the Armacell Group and is registered in the European Union and other countries.
00006 | ArmaGel HT / HTL / XGH | InstManual | 032025 | Global | EN MASTER

ABOUT ARMACELL

As the inventor of flexible foam for equipment insulation and a leading provider of engineered foams, Armacell develops innovative and safe thermal and mechanical solutions that create sustainable value for its customers. Armacell's products significantly contribute to global energy efficiency making a difference around the world every day. With more than 3,300 employees and 27 production plants in 19 countries, the company operates two main businesses, Advanced Insulation and Engineered Foams. Armacell focuses on insulation materials for technical equipment, high-performance foams for acoustic and lightweight applications, recycled PET products, next-generation aerogel technology and passive fire protection systems.

For more information, please visit:
www.armacell.com/armagel

